

THE IPSOS REPUTATION COUNCIL

FINDINGS FROM THE FOURTEENTH SITTING

Exploring the latest thinking and practice in corporate
reputation management across the world

LEADERS IN REPUTATION RESEARCH

GAME CHANGERS



ABOUT THE IPSOS REPUTATION COUNCIL

ESTABLISHED IN 2009, THE IPSOS REPUTATION COUNCIL BRINGS TOGETHER SENIOR COMMUNICATORS FROM SOME OF THE MOST RESPECTED CORPORATIONS IN THE WORLD.

The Reputation Council's mission is to increase understanding of the issues and challenges facing communicators in the corporate environment, as well as capturing expert views on key trends, issues and events in the wider world. Each sitting of the Reputation Council provides a definitive guide to the latest thinking and practice in the corporate communications world. The fourteenth sitting of the Reputation Council involved 150 senior communicators based in 19 different countries.

With thanks to our global Reputation Council members for contributing to our latest edition – without your contribution, this report would not have been possible.

150 interviews conducted with Reputation Council members between 13th September 2019 and 31st January 2020.

All 150 interviews with corporate communicators were conducted face-to-face or by telephone.

The graphs may not add to 100, this is down to rounding or not showing don't know responses

WELCOME TO THE LATEST BRIEFING FROM THE IPSOS REPUTATION COUNCIL

OUR FOURTEENTH SITTING INVOLVES 150 SENIOR COMMUNICATORS FROM 19 COUNTRIES – MAKING THIS A TRULY INTERNATIONAL VIEW.

In a world of constant disruption there has never been a greater need for companies to actively engage with their stakeholders and wider civil society. For many, issues such as climate change, sustainability and social cohesion are no longer climbing the corporate agenda – they have reached its summit.

Indeed, it seems that even 'hard-headed' stakeholders such as investors no longer assess the reputation and investment appeal of a company solely through key financial ratios. They want to see evidence of a company's broader role in society, not least because it is seen as an essential part of any sustainable business model.

We therefore took this opportunity to explore the degree to which Council members felt that the escalation in the importance of sustainability was becoming more pervasive in the corporate environment. We also asked them to highlight industries that were under

the sustainability spotlight the most – as well as examples of companies that stood out as being at the cutting edge of best practice.

Many Council members asked us to include a section on communications planning in this year's report and we were happy to oblige. In this edition we look at the major elements of the planning process, including timing, key inputs, the degree of distinction between internal and external communications and major challenges the communicator faces – now and in the future.

Part of communications planning is of course setting goals, and the management maxim that if you can't measure it you can't manage it, which quickly leads us to the topic of data. We were not only interested in the types of data sources Council members used, but also the way in which they integrated their data sources to provide strategic reputation insights.

We also wanted to understand the range of stakeholders Council members engaged with – if they prioritised distinctive groups, created tailored messaging and whether they were specifically targeting social media influencers: and if so, what techniques they used.

Finally, we decided to retain our quick-fire section from last year's report. We asked Council members questions on a variety of subjects, such as the role businesses play, relative to the government, in fixing society's problems and whether fake news and disinformation pose a material threat to business.

















My thanks to all members for participating in our fourteenth sitting of the Reputation Council and please do get in touch if you would like to discuss any of the issues we've covered.

MILORAD AJDER

**Global Service Line Leader
Ipsos Corporate Reputation**

GLOBAL PERSPECTIVES ON SECTOR REPUTATIONS

WHICH OF THE FOLLOWING INDUSTRIES ARE FACING THE GREATEST REPUTATION CHALLENGES AT THE MOMENT?

-  Aerospace
-  Financial Services
-  Pharmaceuticals
-  Agriculture
-  FMCGs
-  Retail
-  Automotive
-  Government
-  Technology
-  Construction
-  Health
-  Telecommunications
-  Energy
-  Media
-  Tobacco
-  Engineering
-  Mining

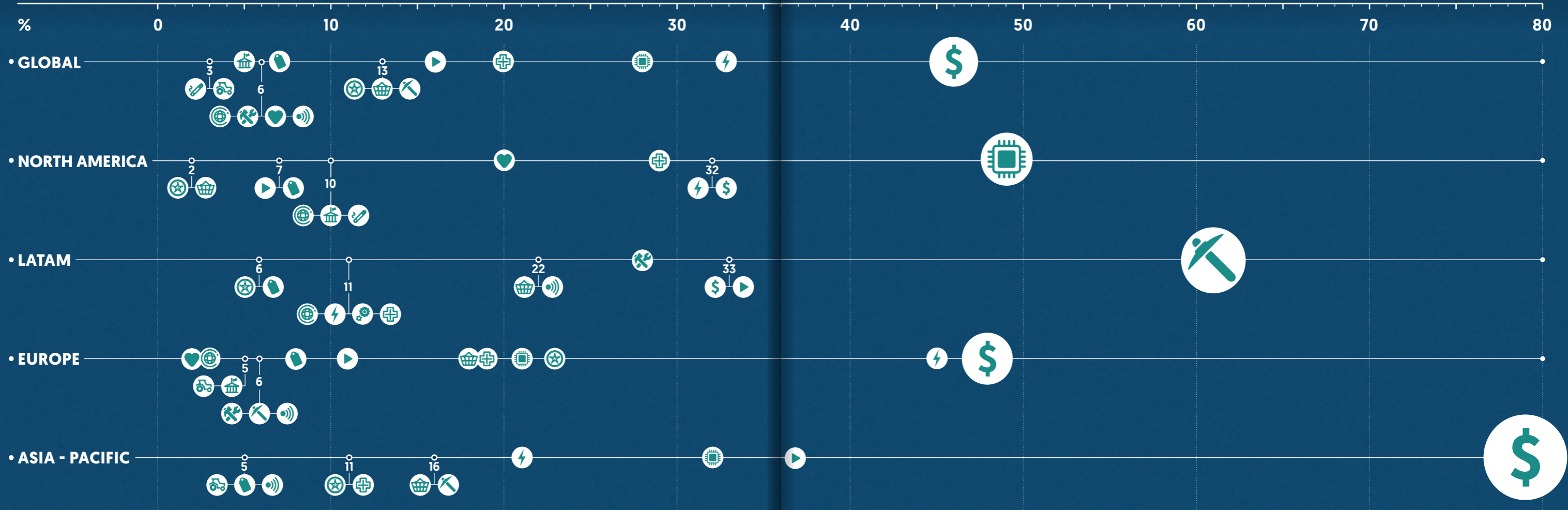

Base: All Reputation Council members – Global [141], North America [41], LATAM [18], Europe [62], Asia-Pacific [19]

NORTH AMERICA

 **49% TECHNOLOGY**

 **32% ENERGY**

 **32% FINANCIAL SERVICES**

Unsurprisingly, in light of the current media and public policy agenda, Council members in **North America see the tech industry as facing the greatest reputational challenges – the view of 49%, up from 44% last time.**

They say **“Techlash”** issues around monopoly status, data privacy and tax are driving the conversation about this industry.

The financial services sector [a **“perennial player”** in this ranking, says one Council member] continues to face a very bright spotlight; so too does the energy industry. Council members expect the pressure on both these sectors to deliver credible Environmental, Social, and Governance [ESG] responses to be even more intense in the near future.

“**So, companies like (Tech companies) which are starting to be hugely criticized in the USA, that was not the case before; about issues of freedom of speech, monopoly position, tax evasion... There’s a growing visibility of all this.**”

“**(Energy industry) Accused of moving too slow on key issues like climate change.**”

EUROPE

 **48% FINANCIAL SERVICES**

 **45% ENERGY**

In our previous report, Council members in Europe named finance and energy as the sectors facing the biggest reputational challenges; there are no signs of that trend abating in

2020. The reasons are well-rehearsed: for energy, the **“acceleration of the global dismay around climate”**, especially among the young; for finance, technological disruption, demands for more transparent products and long-standing issues about trust [**“the public has a long memory”**]. Notably, in Europe a variety of other sectors – pharma, FMCG, tech and automotive – also receive a

number of mentions, suggesting that reputation challenges are not confined to just one or two industries in today’s turbulent world.

“**Obviously the entire banking sector: each time the trigger is a big scandal that crystallizes things, so does its opacity and the fact that it’s a sector that generates a lot of money.**”

LATAM

 **61% MINING**

 **33% MEDIA**

 **33% FINANCIAL SERVICES**

In Latin America, 3 in 5 Council members cite mining as the sector facing the biggest reputational challenges this year (61%, up from 34%). Some notorious human and

environmental disasters account for this climb, along with intensifying debates about the true impact of extractives on society and the planet.

Media and Finance (both 33%) complete the top three. Media independence, against a backdrop of misinformation is a concern for Council members, along with the role of traditional media in a digital world. Financial firms are also seen to face digital challenges, along with some specific

trust issues (e.g. money laundering) and residual stigma from the financial crisis.

“**Mining, because of the disasters. They questioned the practices that were seen by the companies as of concern with the environment, safety, people suitability, the contingency plan, all this was questioned, based on positionings we used to adopt very passively.**”

ASIA - PACIFIC

 **79% FINANCIAL SERVICES**

 **37% MEDIA**

As in the previous two waves, the finance sector is singled out by a large majority of Council members. This view is centred on Australia, as the industry digests the implications of the Royal Commission, but across the region issues of regulatory

scrutiny, complexity and the impact of fintech make this the sector to watch, from a reputation perspective.

Some way behind is the media, especially news media, although these elicit fewer mentions than last year. Business model transformation remains a challenge, in the face of digital platforms and niche media, along with continuing trust issues driven by fake news and politically-divisive reporting.

“**The (finance) sector will remain highly scrutinised for a long time due to its enormous reach and complex landscape. The government will continue to stand up for customers who use their services and holding corporates to account. But this paralyses the market because people will be waiting for the government to intervene.**”

Base: All Reputation Council members – Global [141], North America [41], LATAM [18], Europe [62], Asia-Pacific [19]

CONTENTS

12 - 21

SHARED VALUE:
THE CORPORATE
IMPERATIVE

24 - 33

KEY AUDIENCES:
STAKEHOLDERS
& INFLUENCERS

36 - 45

EXPECTING THE
UNEXPECTED:
COMMUNICATIONS
PLANNING IN A
DISRUPTIVE
ENVIRONMENT

46 - 51

EMBARKING ON
THE DATA JOURNEY:
SMOOTH SAILING

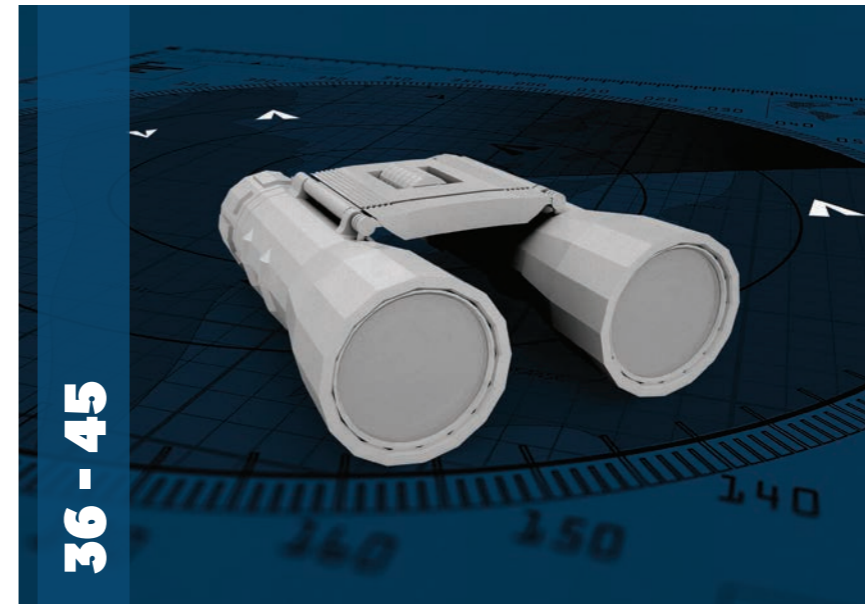

QUICK FIRE

10 - 11

BUSINESS
COMMUNICATIONS:
'EMOTION OVER REASON?'

22 - 23

CHANGING
EXPECTATIONS:
'A BROADER ROLE
FOR BUSINESS?'

34 - 35

BOARDROOM
CONCERNS:
'DISRUPTION
AHEAD?'

BUSINESS COMMUNICATIONS: 'EMOTION OVER REASON?'



DO TOO MANY BUSINESSES USE THE LANGUAGE OF SOCIAL PURPOSE, WITHOUT COMMITTING TO REAL CHANGE?

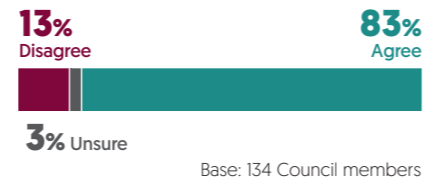

Four in five Council members agree that 'purpose-washing' is still more prevalent than genuine commitment to change. True purpose has to have a cost, or is easy to fake. Increasingly, businesses are being held to account if their actions don't match their rhetoric: as one member put it, "don't be a thought leader, be an action leader."

“I think we might have got away with it in the past, if you think about it, but that is not going to happen as we move forward. People are going to be very discerning about whether they think we are being authentic and ultimately trustworthy and whether you will be able to build a reputation off that.”

ARE TECHNICAL EXPERTS NOW MORE EFFECTIVE CORPORATE SPOKESPEOPLE THAN CEOS?

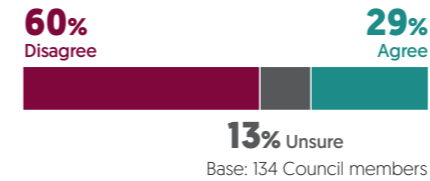

Council members say this is situational – the most effective spokesperson will be determined by the issue, the audience and the industry context. The CEO will often have a broader command of the agenda, and perhaps the charisma or gravitas required for more strategic communication. Conversely, technical experts can elicit greater trust as 'people like us'; a number of members feel they are underutilised.

“The CEO still plays a massively important role in terms of being the figurehead and secondly culture and setting the agenda for the organisation. So good CEOs will always be more effective, but a technical person has a very valuable supporting role to play.”



IN THE POST-TRUTH WORLD, MUST CORPORATE COMMUNICATORS APPEAL TO EMOTION, NOT REASON?

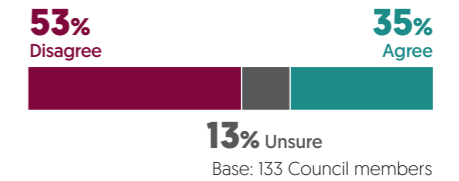

Today, as people struggle to decide what, and whom, they can really trust, Council members are adamant that hard facts, reason and rationality are more important than ever. But these have to be brought to life with appeals to human interest and values, if they are to connect and cut through. As one Council member said, today's communicator has to command both logic and magic.

“I think we have gone from no emotion to full emotion and now we are coming back. They have seen emotion and they have seen reason and now they want to see that together.”



DO BUSINESSES SPEND TOO MUCH TIME BROADCASTING AND NOT ENOUGH TIME LISTENING?

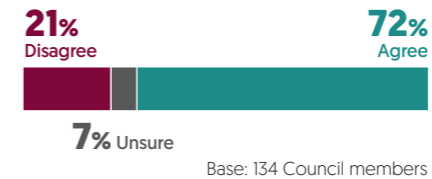

This prompted Council members to reflect that communication is a two-way process, and a tricky one to do well. Resources are finite, so businesses can't listen to everything – and can engage with even less. Being equipped to distinguish the signal from the noise is key. Overall, though, most Council members are optimistic that businesses are committed to listening – and getting better at it.

“You are caught in your bubble, you say what you think people want to hear, you never actually try to understand what they want.”

SHARED VALUE: THE CORPORATE IMPERATIVE?



As the demand for businesses to create shared social and environmental value increases, and the climate change doomsday clock counts down, Council members are seeing corporates coming to terms with their role

in society. But businesses face significant challenges in closing the say-do gap and meaningfully embedding sustainability in their strategies and business models.

“The need for companies to deliver genuine value, as opposed to tokenistic corporate responsibility policy, that’s built into the company’s core purpose is becoming increasingly pronounced.”

The US Business Roundtable (BRT) last year dropped its commitment to “shareholder primacy”¹ in favour of shared value. Accordingly, and by the “modern standard for corporate responsibility,”² businesses must focus on creating value for all stakeholders, including consumers, employees, supply chains, governments, civil society and the planet, as well as shareholders.

Some commentators treated the BRT’s statement with scepticism – Larry Summers, for example described it as a “rhetorical embrace”³ aimed at warding off real regulatory change.

Or as old news – since at least the 1960s, organisations have had Corporate Social Responsibility (CSR) policies with the broad goal of, “contributing to the well-being of the communities and society they affect and on which they depend.”⁴

But for many Council members, the BRT’s announcement does signal something real and burgeoning. Shared value is not the same as CSR, it’s argued. While CSR is essentially philanthropic and extrinsic, shared value requires that environmental and social value become functions of a business’ operations themselves.

It’s this shift, say members, that poses a major challenge. It raises profound questions about what exactly shared value looks like, and how to measure it? How fundamentally should or can businesses adapt? And how quickly? And how to communicate intrinsic changes in a way that cuts through with stakeholders?

“Companies are trying to figure out the balance between responsibility to shareholders and to society. We were doing positive things before the BRT statement, but it has brought focus.”

“The debate has been going in that direction for the thick end of a decade, at least in terms of talk. So, the reaction is, “yes of course,” and the next question is, “what are you going to do about it?”



* For references in this article please see page 21

THE INCREASING DEMAND FOR MEANINGFUL ACTION

In dropping a credo it's held since 1997, the BRT is reacting to demand for environmental and social action that is radically increasing. Much of this demand is directed at business.

To complicate matters, it comes from multiple stakeholders across many issues. The UN Sustainable Development Goals, for example, cover 17 areas of sustainable development, from sanitation to gender equality to education. Every one of these to a greater or lesser degree presents a challenge for businesses. Each is a potential lens of scrutiny, with discoveries likely to be amplified and distorted online.

Expectations of corporate citizenship have increased. Last year, more than half of Council members (56%) said that consumers expected them to take a stand on socio-political issues, against only a quarter (23%) who disagreed.⁵

“*I think we live in a new and much more complex world within which it isn't just shareholder value that means everything. I think corporates are generally aware of their place in society now more than ever.*”

For some members, the driving force behind this change is **the millennial generation** (born around 1980-2000) – which, based on some projections **will make up 75% of the global workforce by 2025** – flexing their muscles as citizens, consumers and of course employees.

“*You have work forces, in particular the millennial work forces, that are legitimately concerned about sustainability and corporate responsibility in terms of whether they want to work for a company.*”

But there's evidence that the investment community is catching up. Increasingly businesses are evaluated on non-financial, Environmental, Social and Governance (ESG), metrics alongside more traditional financial metrics. BlackRock CEO Larry Fink's recent letter to investors claims that, “**investors are increasingly reckoning with these questions and recognizing that climate risk is investment risk.**”⁶ And BlackRock now claims that, “**sustainable investing is the strongest foundation for client portfolios going forward.**”⁷

IN THIS WAVE, MORE THAN HALF OF MEMBERS (57%) SAY THAT BUSINESS LEADERS ARE NOW OVERTAKING POLITICIANS AS A FORCE FOR PROGRESSIVE CHANGE IN THE WORLD (PAGE 23); WOULD THIS HAVE BEEN THE CASE JUST 10 YEARS AGO?

The factor that really “**changes everything,**”⁸ however, that underpins the shift to shared value, is climate change. It is both an existential threat and, “**the wickedest kind of problem imaginable: complex, interconnected, and requiring massive collective action.**”⁹ It raises the stakes for what counts as value, and makes demonstrable action and impact a necessity for any organisation. It makes ‘greenwashing’ a threat to reputation rather than an asset. In sum, “**climate change has become a defining factor in companies' long-term prospects.**”¹⁰



“*All of us can see that the investment community is really much, much more interested now in the way that businesses operate beyond just the financials. Financials stay important but it is about how people do business and we see that all the time in our analyst briefings or when we go out to meet the investment houses.*”

“*Because of the actions of Greta Thunberg and the Rebellion that Extinction the environment has placed on all businesses have got to take responsibility and accountability for sustainability.*”

“*This is how sustainability is moving – from communications to true business. Greenwashing was about communication, now the finance industry thinks of sustainability as financial survival.*”

“*Investors rate us on our sustainability practices. I think that today everyone has a sustainability imperative.*”

THE SAY-DO GAP



A study by Boston Consulting Group and MIT in the US in 2016 found that, while 90% of executives described sustainability as important, only 60% of companies had incorporated it in their strategy, and just 25% had it incorporated in their business models.

Four years on, for many Council members, particularly outside Europe, crossing this chasm from recognition to meaningful action remains a key challenge.

“I think companies are finding it quite hard after the first wave of enthusiasm for green topics, where they said lots of nice things, to embed that into what they actually do day to day.”

“At present, keywords such as Sustainable Development Goals are flying around in Japan and there is consciousness about instilling social purpose into business purposes, but I think that many companies are wondering how to do it.”

While the majority of Council members consider the shift towards shared value to be a long-term trend, there is much less agreement that a company's performance on sustainability is currently important in determining valuation.

As these responses reveal, the say-do gap is partly based on a perceived tension between short and long-term

priorities. Still, for many businesses, financial and sustainable aims are seen as different in kind. Companies and CEOs are seen to live or die based on financial metrics, and investors care far less about an organisation's performance on ESG metrics.

On a scale of 1 to 5, how important is a company's performance on sustainability in determining its valuation (share price)?

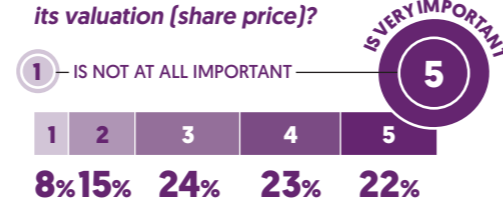

Base: 120 Council members

The US Business Roundtable, consisting of CEOs from some of the country's biggest companies, recently issued a statement saying that shareholder value was no longer the overriding corporate priority and that companies should have a broader social purpose and remit.

Base: 115 Council members

Do you see this as a long-term trend or something that could be reversed if economic conditions deteriorate?



“Some hedge fund managers may be more interested in immediate returns, as opposed to pension funds that want long-term sustainable returns which can only come if a business is planning to be sustainable.”

“If your business is run through short-term measures all the time, would you ever put money into doing something that might not return an investment for 5 years, when CEOs are only there for 3 years?”

“If economic conditions deteriorate, unless you can show immediate ROI or growth because of the strength of being sustainability-oriented, you're going to see companies get right back to basics.”

Understood in this way, sustainability and purpose remain a risk and a cost to businesses.

Meanwhile, the Harvard Business Review enumerates the benefits of

creating shared value: competitive advantage through stakeholder engagement, improving risk management, fostering innovation, improving financial performance and building customer loyalty.¹¹ And at the same time, there are plenty of warnings about the long-term threats of failing to adapt. For example, the outgoing governor of the Bank of England warned businesses in 2019 that those who don't move towards zero-carbon emissions will ultimately go bankrupt, “without question.”¹²

So, what our Council members highlight is that, while there's a growing long-term business case for focusing on shared value, the shift in mindset required to set this in motion is proving difficult in the short-term.

APPROACHES TO CLOSING THE SAY-DO GAP

Clearly, the scale of this challenge differs by company and industry. In some cases, there appears a fundamental tension between historical business models and sustainability – for example, in extractive industries or ‘fast’ fashion. This inevitably impacts the rate of change. But the lesson from Council members, is that companies that are performing well on sustainability are at least moving towards, **“a sustainable approach that is not an add-on but is integral, integrated to their business and their strategy and their purpose.”**

EXAMPLES GIVEN BY COUNCIL MEMBERS OF BUSINESSES THAT STAND OUT AS BEING AT THE CUTTING-EDGE OF SUSTAINABILITY TEND TO FALL INTO ONE OR MORE OF FOUR CATEGORIES.

01. DELIVERING SUSTAINABLE PRODUCTS

For some businesses, sustainability is the key feature of a product. Council members cite Tesla’s electric cars as a good example of this type. Oil companies that are investing in renewable energy also fall into this category, though there is a long way to go before they become providers of a sustainable product. The technology sector may count, as it focuses on offering the technology to underpin sustainability efforts of others.

02. CLEANING UP SUPPLY CHAINS

As the focus on sustainability increases, supply chains continue to be a problem for many companies – sourcing of resources, labour conditions, air miles. Innovation in packaging also falls under this banner, in that by reducing the use of plastics, businesses are aiming to reduce a harmful by-product of distribution. For Council members, Unilever, Nestlé and Coca-Cola are good examples of businesses focusing on this area.

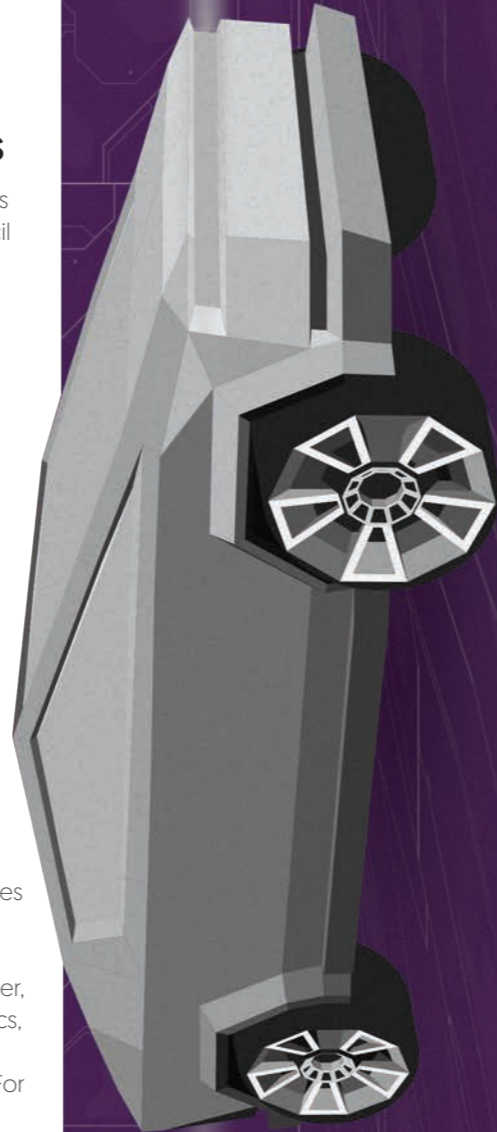

03. COMMITTING TO OBJECTIVE TARGETS

Several companies identified by Council members have made commitments that align to external standards. Microsoft, for example, has committed to aligning its operations with the UN’s recommended target of 1.5°C global warming by 2030, a commitment certified by the Science Based Target Initiative (SBTi). Danone is aiming to become a B corporation, thus will be legally required to consider the impact of their decisions on their workers, customers, suppliers, community, and the environment.

04. BECOMING CORPORATE ‘ACTIVISTS’

Some companies are conspicuous in supporting particular external causes. Patagonia is a flag-bearer for this approach, committing a percentage of its revenue to support grass roots climate movements. Though clearly it could not do this if it did not also commit to other behaviours [e.g. clean supply chains]. Another example would be Coca-Cola, which directly supports the Global Environment and Technology Foundation’s work in Africa to replenish water sources.

Each of these approaches does something to incorporate sustainability into strategy or business model, and offers established paths for other companies to start to cross the say-do gap towards shared value. And the greatest value, of course, is likely to be delivered through a combination of these approaches.



KEY PRINCIPLES

COUNCIL MEMBERS IDENTIFY SEVERAL PRINCIPLES THAT UNDERPIN ANY OF THESE STRATEGIES:



01. MAKE COMMITMENTS THAT INSPIRE

Commitments need to be fundamentally meaningful, credible and inspiring to a range of stakeholders, including governments, customers, employees and investors. Every business needs to assess what issues it is best placed to address and whether these issues are really the important ones for its stakeholders. And all businesses need to make commitments on climate change. To do these things, they must be prepared to innovate.

02. MEASURE SHARED VALUE

There's an adage: **"what gets measured, gets managed."** Measurement of stakeholder opinion should also inform strategy and communications, while helping provide evidence of the effectiveness of a business' commitments. Council members see ESG-style measurement as key, in that it links directly to the financial performance of businesses and CEOs.



“ Above all, as one Reputation Council member puts it, the future must be ‘action-leadership’, not just ‘thought-leadership.’ **”**

03. EVIDENCE-BASED COMMUNICATIONS

There is broad agreement that greenwashing is finished. Communications should be evidence-based, and tailored to the priorities of different stakeholder groups. Commitments should be embedded in the corporate narrative that companies tell internally and externally.

REFERENCES

- 1 - <https://www.businessroundtable.org/business-roundtable-redefines-the-purpose-of-a-corporation-to-promote-an-economy-that-serves-all-americans>
- 2 - Ibid
- 3 - <https://www.ft.com/content/e21a9fac-clf5-11e9-a8e9-296ca66511c9>
- 4 - <https://hbr.org/2015/01/the-truth-about-csr>
- 5 - <https://reputation.ipsos-mori.com/taking-a-stand/>
- 6 - <https://www.blackrock.com/corporate/investor-relations/larry-fink-ceo-letter>
- 7 - Ibid

IN SUMMARY:

021

01. Businesses are facing significant challenges in moving from CSR to creating shared value.

02. While businesses recognise the long-term importance of shared value, there is a tension for some between this and short-term priorities; this tension underpins the say-do gap.

03. There are existing paradigms to help companies begin to cross this gap: focusing on sustainable products, cleaning up supply chains, making meaningful commitments or engaging in corporate activism.

- 8 - This Changes Everything: Capitalism vs. The Climate, by Naomi Klein
- 9 - Can Business Save the Earth? Innovating Our Way to Sustainability, by Aaron Chatterji and Michael Lenox.
- 10 - <https://www.blackrock.com/corporate/investor-relations/larry-fink-ceo-letter>
- 11 - <https://hbr.org/2016/10/the-comprehensive-business-case-for-sustainability>
- 12 - <https://www.theguardian.com/environment/2019/oct/13/firms-ignoring-climate-crisis-bankrupt-mark-carney-bank-england-governor>

CHANGING EXPECTATIONS: 'A BROADER ROLE FOR BUSINESS?'

IS IT THE JOB OF GOVERNMENT, NOT BUSINESS, TO FIX SOCIETY'S PROBLEMS?

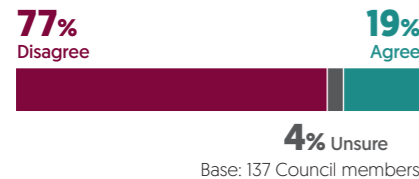

Three quarters of Council members see a clear societal role – and responsibility – for businesses. However, this should be as part of the solution, in partnership with governments and other stakeholders, and aligned with the company's “skill set and intellectual capital”. Agenda-setting must still reside with democratic government; however, corporates can often call on greater financial muscle-power and ‘street-level understanding’, to implement change.

“Because business has a role and responsibility in the world today, given the amount of money we bring to the economy. It can no longer be that we are just there to make money, we have to have a legacy and we have to be able to answer the question ‘would the world be better or worse off without us?’ If we can’t answer that, we probably shouldn’t be in business; it is our duty and responsibility.”

ARE BUSINESS LEADERS OVERTAKING POLITICIANS AS A FORCE FOR PROGRESSIVE CHANGE IN THE WORLD?

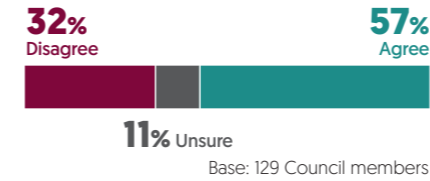

Nearly three in five Council members agree that, nowadays, it’s not unusual to see business leaders flex their muscles as agents of social change. Some may be emboldened by front-runners like the US Business Roundtable and BlackRock’s Larry Fink. Up for debate: whether this is really new; what it tells us about today’s political class; and whether leaders are really willing to redraw their fundamental business models?

“We do see companies taking stands and we’re seeing some change. But we’re not at a point where most of your ‘average Americans’ are going to see big changes in their lives.”

DOES BIG BUSINESS STILL NOT TAKE BOARDROOM DIVERSITY SERIOUSLY?

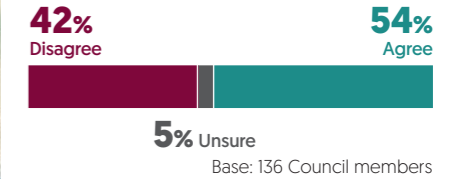

While Council members’ opinions appear divided, in fact there’s a commonly-held view that businesses do take diversity seriously, particularly around gender equality, but haven’t yet made enough progress – “it’s hard. The problem has been 30 years in the making and we are trying to fix this in five.” Interestingly, more than a few members feel their own company is making better progress than the corporate world as a whole.

“They do take it seriously because they have to take it seriously, there’s legislative and regulatory reasons, but is it moving quickly enough, and are we seeing diversity, no.”

KEY AUDIENCES: STAKEHOLDERS & INFLUENCERS

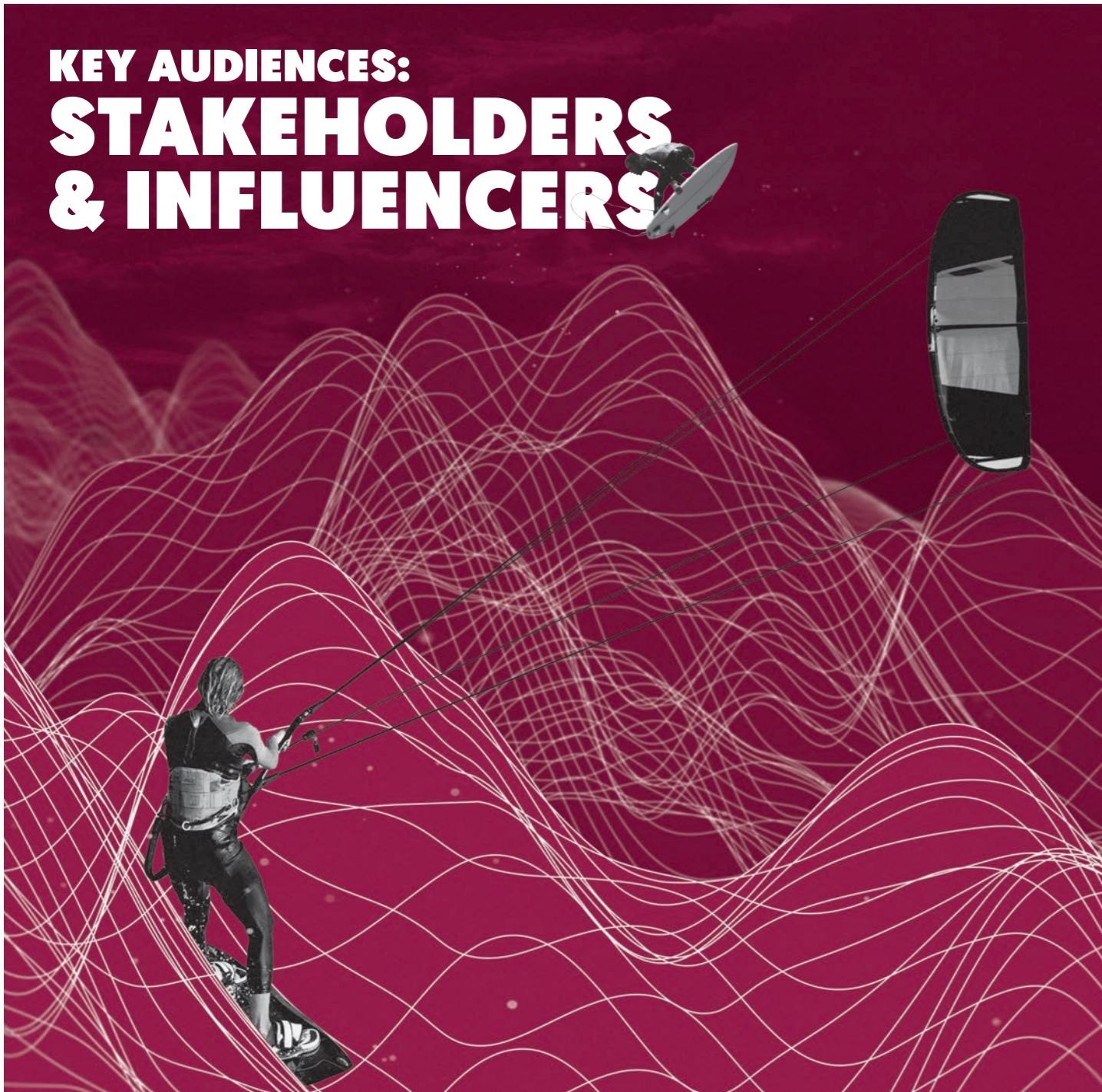

It is clear from our conversations with Council members that the profile, influence and importance of stakeholder groups are continually shifting and evolving. The vast majority of Council members name several stakeholder groups that have become increasingly important in recent years. Many point to the emergence and growth of some new influential audiences, driven by social media

giving a louder voice to a wider group of audiences, including the public;

“ It gets back to the whole social media piece. Everyone has a megaphone and can be heard. We have to pay closer attention and be more nimble to respond and engage.

While recognising the growth in new influential stakeholders, many Council

members also stress that this has not diminished the role and importance of traditional stakeholders [e.g. in government or media]. Interviews highlight that it's not a case of new stakeholders pushing aside the old players, but instead that there is now a larger range of influential stakeholders for corporate communicators to engage and manage.

STAKEHOLDERS THAT HAVE BECOME MORE OR LESS IMPORTANT

Q. Would you say that any particular groups have become significantly more important or influential, in recent years?
Q. And have any become significantly less important or influential?

TOP MENTIONS (SIZE OF CIRCLES ARE RELATIVE TO NUMBER OF MENTIONS)

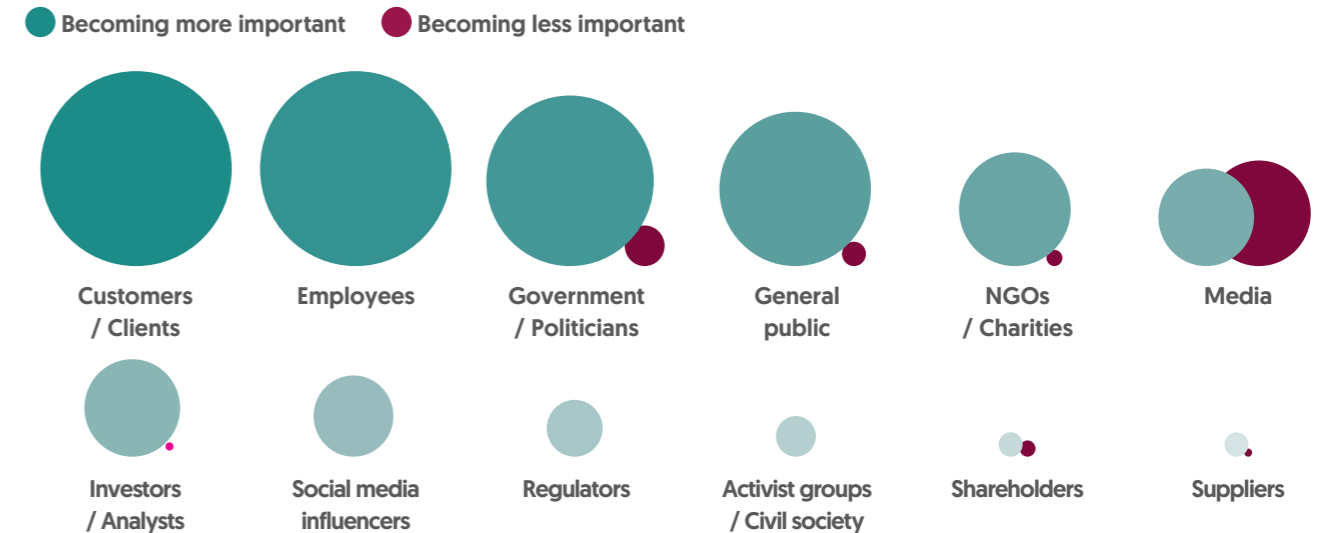

Base: 112 Council members

WHICH STAKEHOLDERS ARE BECOMING MORE / LESS INFLUENTIAL?

As shown on the following pages, a range of different audiences are recognised by Council members as becoming more influential, but leading the way are customers and employees, closely followed by government/politicians and the general public. Non-governmental organisations (NGOs), journalists and investors are also commonly mentioned.



CUSTOMERS

While many explained the increased importance of customers as being the audience which ultimately buy their products and services [“**We’re not an NGO, we’re not the government, we’re a company that makes products. We’re here to serve the customers.**”], others point to the fact that customers are becoming more aware and vocal on socio-political issues;

“**Customers, maybe over the last 10 years, have become more important than ever, only because they are such an important voice in a lot of the debates on health or the environment or packaging or whatever it might be.**”

Similarly, the wider public’s influence is growing as they become more

organised and sophisticated in getting their voices and views heard on socio-political issues;

“**The informed public, the political and socially interested ones have not really played a part in the past but have now become more important.**”

Several corporate communicators observed the growth of “**individual activists**”, highlighting the influence that one voice can now have;

“**One of the areas we have seen massively grow is individual activism and how that can actually be really quite challenging...as a company, we are not set up to meet with all these individuals because otherwise that is all we**

will do. And it has really required us to look at what information can we produce that will be easy to send to these individuals and engage with them but not necessarily require us to have meeting after meeting after meeting.

While engaging with an individual is one solution, many also turn to NGOs as a partner to help influence the views of activists and “**shape the external landscape**”. NGOs are also seen to be increasingly important to understand the views of consumers while also providing, as one member stated, “**a useful sounding board for us as we are developing plans**”. Just like the wider public and individual activists, NGOs are becoming increasingly organised and influential on socio-political issues.

EMPLOYEES

Closely related to the growth of individual activism and engagement, is the extent to which employees are now taken “**much more seriously as a sophisticated stakeholder audience**”.

“**Employees have risen to the top as far as important audiences. They were an afterthought, even a couple of years ago. Understanding that employees are at the heart of an organization – that they’re the ones who drive the culture and the results – is definitely a trend.**”

Employees are increasingly being thought of as credible communicators which companies need to “**help empower as potential ambassadors for the business**”. There is also a recognition that taking good care of the workforce can lead to a better-run company and being able to recruit the best possible talent.

Our research shows that employees are seen to be a trusted source of information. Organisations should therefore leverage the potential influence that their employees hold as credible communicators.

However, to do so, employees need to be both empowered and enabled. Similarly, employees need to receive enough knowledge about their organisation’s values and aspirations, so they feel confident enough to discuss these with others. Messaging should be aligned across the business and succinct in layman’s terms, so that it can be easily digestible and easily relayed by employees. Inviting external stakeholders to facilities or events where they can engage with employees is also viewed as an effective way to give voice to this increasingly important group.



GOVERNMENT / POLITICIANS

Despite being considered a traditional stakeholder audience, many corporate communicators report that politicians are increasingly important to them. As with the public and NGOs, some politicians are also increasingly vocal and impactful through their use of social media platforms, and occasionally the views shared on such platforms can be disruptive, damaging and misleading;

“**Government has gotten more vocal. They were always important, but now they're very reactionary, so you have to be able to anticipate what they will be reactionary about.**

“**Customers [are] more informed and empowered, but sometimes**

they do not have enough information to analyze properly. Politicians are taking advantage of some distorted information in an opportunistic and populist way.

Politicians' ability to determine license to operate is also cited as a key consideration, with corporate communicators working hard to ensure their company's views are heard in policy and regulatory discussions;

“**We actually don't want to be the one that the politicians have in their sights, but we do want to make sure that we're at the table contributing to the policy discussion.**

Council members note that the importance of politicians ebbs and flows depending on elections and other key political events. During a normal election cycle, the work of corporate communicators is strategic and deliberate, whereas when things are more unpredictable at election time **“there is almost no point... because there is going to be such a huge turnover...when we get through the election there is a huge task to be done in terms of mapping your stakeholders and working out where the balance of power lies and where we need to focus.”**

With increased political uncertainty around the globe, communicators are having to adapt and evolve their approach for engagement with this important group.



MEDIA

In contrast to views about politicians, there is much less consensus when it comes to the media. Council members are split on the importance of this group, being just as likely to say it's on the rise as to say it is diminishing. Some feel that the media continues to be a key channel of information that can be used to communicate a company's message;

“**I wouldn't underestimate the relationship with traditional media either, you do so at your peril. We try to invest in the right amount of**

time with various traditional media audiences... they are important allies for us.

However, others feel that while traditional media continues to be important, its influence is less than in the past, largely due to the growth of social media and online sources of information;

“**They are still important, but I do think they are less influential than they used to be, definitely they take up less of my time than they**

would have done 5-10 years ago. There are just a lot of sources now online where people use and reuse content and they just don't necessarily want to pay for it.

To a large extent, the perceived importance of the media will vary from across sector, issue and outlet. For communicators in today's environment, the key is knowing which media voices have influence on the issues that matter to your organisation and targeting engagement efforts accordingly.

COMMUNICATING WITH THE PUBLIC

A TAILORED OR ONE-SIZE-FITS-ALL APPROACH?



Considering the growing voice of the public, we asked Council members how they go about engaging with this audience. Members highlight the need for a targeted approach, where budgets allow:

“ I think it’s fundamental to have a specific approach for each audience. Specific to different segments... To move away from something generic and closer to particularities.

This doesn’t necessarily mean that different parts of the general public will receive different messages; in fact, often the messaging across audiences will be aligned, but the formats and

channels of delivering the messaging will vary by audience;

“ We tailor messaging to each audience; however, we have core messaging that our messages all ladder from to create unique messages.

While it is common practice for brand and marketing functions to tailor communications towards their core target customer audience, corporate communicators are also increasingly taking a targeted approach in their communications with the public. While the concept of the engaged citizen and early adopters is not a new one,

it is especially relevant as a means of concentrating messaging towards a group of people who are most likely to absorb the messaging, react to the messaging, and influence the views of others. Understanding the views of these engaged publics can also act as an early indicator of future trends, as they are more likely to be ahead of the curve in terms of their views, awareness of issues, and behaviour;

“ These are the engaged, interested, active people within their local communities and the broader industry circles. If we can reach them, and if they can understand what we’re doing, then that helps create grounds for them.

ENGAGING WITH SOCIAL MEDIA INFLUENCERS

Q. To what extent do you try to understand and engage with social media influencers?

44%
Around two-fifths say they do a lot / regularly

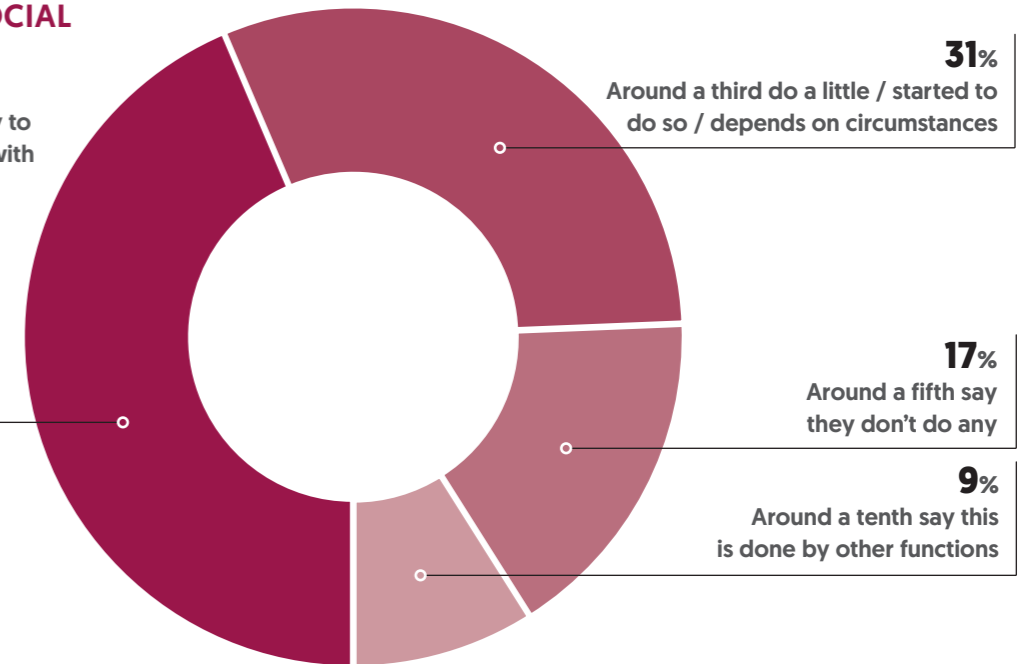

Base: 77 Council members

However, as one Council member points out, it is important to identify and understand the characteristics of the most engaged segment of the public, and to do so regularly as their profile can change over time;

“*The difficulty is in identifying them because they are not the same as they were 20 years ago, 10 years ago, now. So being able to identify the right slice of humanity that can give information in advance, and then gain time for companies. It's a difficult task.***”**

Closely aligned with the increased need to treat the engaged public as a core stakeholder group, is the growing importance of social media influencers;

“*Very important, an extremely important audience because they really have the power to influence both consumption and behaviour. And they influence both from the point of view of selling our products and advancing our causes. Digital influencers are extremely important. I think the digital influencer will gain even more relevance.***”**

When engaging with social media influencers, Council members talk about how they first go about identifying and selecting a small pool of highly relevant and influential individuals;

“*It is about the quality of audience really, are we talking to the right people.***”**

The conversation shouldn't be one-way. While some focus on engaging with influencers as a catalyst or ambassador to get messaging across, it is also worth listening to what influencers and their

followers have to say. As a member states, this can lead to exceptional levels of insight;

“*I have been working with 10 or 15 micro influencers who might have less than 1,000 followers and actually their network can be exceptionally interesting as well because you get some very rich in-depth engagement with some very interesting insights.***”**

However, not all corporate communicators engage with social media influencers. Some feel that the financial costs are too great or that social media influencers are “less impactful now”. One Council member also warns of the danger caused by interacting with such influencers, pointing to the risks of handing over control of your reputation to social media ambassadors, and emphasising the need for careful monitoring when going down this route;

“*Every time you interact with someone, you create a contract with someone, you are transferring the responsibility to that person. In other words, I would need to closely monitor the integrity, the behaviour of my ambassadors.***”**

Similarly, it is important to underline the fact that Council members are far less likely to name social media influencers as an increasingly important stakeholder group than they are to name other audiences such as employees, politicians, the wider public and NGOs. Indeed, while social media has undoubtedly been a driver of change, Ipsos Corporate Reputation's experience of working with stakeholder audiences highlights that direct engagement remains the most effective way to ensure a voice on your key issues.



CONCLUSIONS

The increased breadth and influence of the stakeholder audiences with which communicators must now engage highlights the fact that building and protecting corporate reputation is a complex challenge. Communicators need to be adept at determining the difference between noise and influence, with resources directed accordingly to ensure effective relationships are built with the stakeholder groups that matter most. In mapping out their stakeholder audiences, the relative importance of each group should be determined by its level of influence over the issues affecting an organisations' reputation, rather than the channel through which the influence is created. This is reflected in the experiences of Council members where traditional stakeholders are given as much consideration as emerging influencers. As technological change continues to give voice to new audiences, the ability to map, understand and prioritise stakeholder audiences will become increasingly important in determining corporate communications success.



BOARDROOM CONCERNS: 'DISRUPTION AHEAD?'

IS OUR CORPORATE REPUTATION A BOARD-LEVEL CONCERN?



Base: 137 Council members

Among Council members, this is now a given. The importance of reputation is “**accelerating**” across a number of fronts – governance, risk, employee engagement, commercial performance – as is the role of the CCO as trusted advisor to the board on reputation. However, some members point out that reputation should really

be the concern of everyone in the business, not just the top tier.

“**Absolutely. Our Chief Operating Officer reviews our corporate reputation quarterly and it is reviewed with our Board of Directors, so it starts at the top and filters all the way down.**”



ARE SOCIAL MEDIA PLATFORMS NOW TOO COMPROMISED TO BE CREDIBLE FOR CORPORATE COMMUNICATIONS?

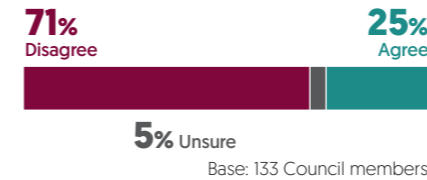

Base: 133 Council members

Despite a widespread view among Council members that certain platforms “**need to clean up their act**”, most are not ready to write the obituary for social media. The reason is simple – this is where stakeholder conversations happen, so businesses have to engage. Indeed, platforms such as LinkedIn

[both for corpcomms, and for linking execs across a business] and Instagram [for storytelling and human interest] are increasing in importance. The golden rules? Fit the platform to the purpose, and be ready to manage the risks.

“**Need to be alert but that’s where our stakeholders are, so we need to be part of that discussion. There is nothing compromised about them. Social media is a huge enabler, I do not have a down on social media.**”

DO FAKE NEWS AND DISINFORMATION POSE A MATERIAL THREAT TO OUR BUSINESS?

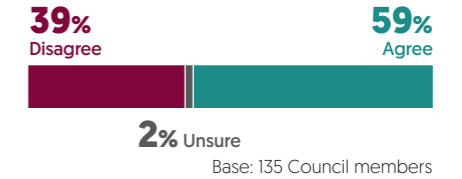

Base: 135 Council members

Three in five Council members agree that fake news is a material threat, but estimates of its severity vary. Few see it as an existential threat, because businesses are adapting to manage the risks, and audiences are learning to distinguish what’s real and what’s fake. But it’s high on the risk register, and not going away any time soon.

“**That is just the sort of ‘what is someone going to say one day about us?’ and how quickly that travels. You can’t predict any of that – you can prepare for it but you can’t predict it. It is the one thing that will keep any comms person awake at night.**”



EXPECTING THE UNEXPECTED: COMMUNICATIONS PLANNING IN A DISRUPTIVE ENVIRONMENT



The success of a communications strategy is in large part dependent on sound planning. Corporate communicators need to ensure that their function is fully integrated in the business. It needs to be capable of both proactively

planning the year ahead whilst remaining sufficiently nimble to react to unexpected and hard-to-predict circumstances that often present communications challenges in the short term.

There are a number of components that make up the blueprint of an effective communications planning cycle.

AMONG THEM THERE ARE:

- Timely actions to support business strategy throughout the financial year
- Insightful inputs to maximise chances of conveying a comprehensive message
- The involvement of appropriate internal stakeholders
- The right balance of aligned and unified internal and external communications
- An ability to adapt to the unexpected

In this sitting of the Reputation Council, we've explored what the key factors are in successful communications planning, the most important changes in how corporate communicators work and the future of the function. In addition, we touch on other hot topics of debate, including the balance between internal and external communications and the timings of the communications planning.

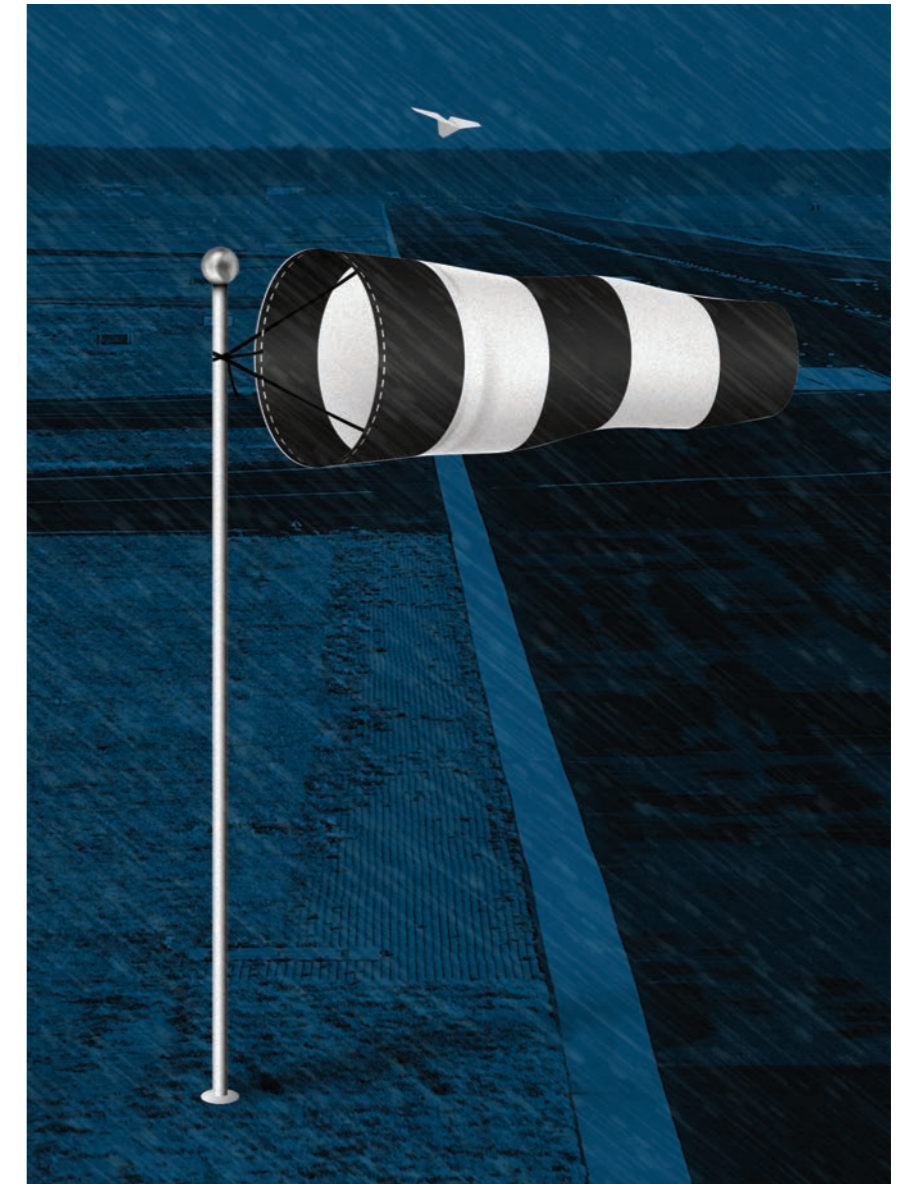

FIVE KEY FACTORS IN SUCCESSFUL COMMUNICATIONS PLANNING



GOOD CORPORATE COMMUNICATIONS PLANNING IS DESIGNED IN CLOSE COOPERATION WITH THE BUSINESS IT SERVES. THERE ARE A NUMBER OF SOURCES OF INFORMATION, BOTH INTERNAL AND EXTERNAL, THAT MEMBERS CONSIDER WHEN PLANNING:

01. BUSINESS OBJECTIVES

Business strategy and priorities for the year ahead are at the heart of communications planning. The overall organisational strategy both short and long-term [i.e. five- or ten-year strategies] shapes both the overarching and tactical comms initiatives.

“*Business strategy from the management department. And financial information from the finance department.*”

02. SENIOR LEADERSHIP

Top management and senior decision makers often have an active voice in shaping the communications strategy of the business. They input their views at any stage of the design and/or signing off the final version of the plan.

“*First and foremost, it's from the general manager and board leadership of that business. We don't plan anything until we've sat down with them and discussed their strategic priorities for the year ahead. I very much view corporate communications as supporting that strategic roadmap rather than telling them what their strategic roadmap should be.*”

03. BUDGET AVAILABLE

Financial constraints are a key factor to consider and corporate communications are often required to maximise impact with limited resources. This is an essential factor in determining the day-to-day execution of the plans.

“*There's the budget process, which is happening now. The amount of money you have to spend dictates some of the things you're going to be doing – so budget dollars.*”

04. EXTERNAL SOURCES

Specialist opinion research, brought in from third party sources to understand the perceptions and expectations of various stakeholder groups, or test the validity of specific campaigns or initiatives is also a common input. It's objective nature makes it particularly powerful in some businesses, as it brings clarity when conflicting internal points of view.

“*External analysis – strategy and insights. What is happening in the surrounding culture, what are the pressures coming at you?*”

05. PEERS

It is often the case that corporate communicators discuss the challenges and opportunities facing their businesses with their networks of peers in the sector. Confidentiality certainly plays a key role here, but Council members often see this as a key way to validate current approaches and discuss fresh ideas.

“*External stakeholders, inside market intelligence, customer intelligence, – several sources are integrated.*”



“*Business operating strategy dictates priorities; research with consumers for the business; financials [opportunities and threats]; business performance.*”

THE MOST IMPORTANT CHANGES IN HOW CORPORATE COMMUNICATORS WORK

The past decade has brought deep transformations to the way organisations are expected to interact with their stakeholders. From day-to-day execution to overall strategies for stakeholder engagement, here are some of the changes most commonly mentioned by Council members:

01. IMMEDIACY

The 24h news cycle requires corporate communicators to react quickly to news stories and have a point of view on critical issues with the potential to affect their organisation's reputation.

“I think the more we globalize, there will be much longer working hours. Especially in communications, the reaction is important. If something happens somewhere it needs to be dealt with. If there is an increase in overseas matters that cannot wait until the next day, I wouldn't say we need to be in operation 24 hours but monitoring them will be tough.”

02. THE SHIFT TO DIGITAL

New communications channels, social media in particular, require corporate communicators to adapt their skillset and nurture more multi-disciplinary teams. There is also the need to coordinate the messaging across platforms and interact with stakeholders in a more direct way than in the past. Ensuring consistency and a single voice is of paramount importance.

“Communication process has changed tremendously, there are fewer journalists, print has decreased in importance, development in fields of digital, social media, podcasts, videos and so on, a new audience is being addressed, the middle man (journalist) is cut out.”

03. STORY-TELLING

Standard press releases are no longer good-enough to get a company's point across. Stakeholders increasingly expect creative story-telling for press officers to stand out from the crowd.

“We've changed how we think about external communications. We've gone from “press release happy” to storytelling outside of the traditional press release. We can't just check off 'press release' - we need to be more creative.”

04. COLLABORATION

These days, communications teams are expected to work closely with

other internal departments. Externally, the communications process has moved from 'broadcasting' to 'dialogue', with stakeholders expecting a higher degree of interaction than in the past.

“There is a breakdown in silos within business and this reflects a merging of communication disciplines. It used to be that internal communications, marketing and corporate communications were really separate areas but with so much blurring of boundaries between those and that has forced a greater degree of collaborative and integrated working which then becomes a bit of a self-fulfilling prophesy because you then get more blurring of boundaries, it just keeps feeding itself as a way of working.”

“Really acting like an agency; bringing the full amount of expertise within the team. You could be working on something that you don't support directly. We try to be as collaborative as we can and bring the expertise that we have in-house to any number of initiatives that we're working on.”

THE BIGGEST CHALLENGES IN THE COMMUNICATIONS PLANNING PROCESS

As the role of the corporate communicator becomes increasingly complex, Council members discuss some of the obstacles they face in their jobs today. The most important are:

01. ALLOWING TIME FOR THE UNEXPECTED

Increased scrutiny of an organisation's activities and a global remit often lead to reputational crises that need to be dealt with decisively. Time commitments vary depending on their severity, but Council members agree on the need to carve out time to cope with unexpected challenges in a volatile environment.

“It's being in such a reactive environment. There are issues and crises that we've had to deal with here. We have protesters. We have environmental issues. We have animal welfare issues. These things tend to pop up relatively quickly and you have to react to them. That, unfortunately, gets in the way of some of the more proactive things that we'd like to do to talk about our reputation and show how we're activating on purpose.”

02. DECENTRALISATION AND COORDINATION

With increasingly complex organisational structures and competing priorities, coordinating processes and messages is a common challenge that needs to be considered. Equally, balancing short and long-term priorities is frequently a difficult exercise.

“Changing priorities, short term objectives... Once we have the strategy and plans, we have to change it.”

03. LOCAL IMPLEMENTATION OF GLOBAL STRATEGIES

With Council members normally being part of leading global organisations, they often find that transposing global messaging into their local context is a delicate process that requires careful consideration to account for cultural differences.

“The biggest difficulty is aligning each global business strategy with each region. The difficulty is that what you see at headquarters is different from what you see locally, so I think it's very difficult to get this alignment. The most common thing is the fact that we have a global team and the local team brings the raw information from the locals.”

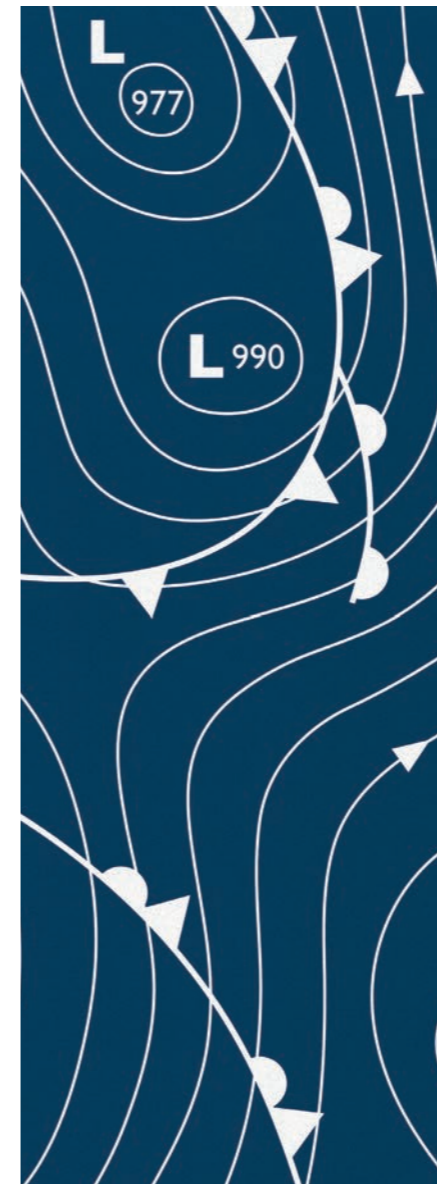

THE DISTINCTION BETWEEN INTERNAL AND EXTERNAL COMMS

The distinction [or lack of] between internal and external communications has been a hot topic of debate in the industry for a number of years.

On the one hand, the need to tailor communications to the different needs of internal and external stakeholder groups makes the case for separate work streams. For example, employee communications require a different approach to that needed with investors. Whilst the company needs the support of both groups to succeed in the marketplace, their experience of an organisation is vastly different. It is also a 'fact that it is easier for the company to control internal communications channels than it is to shape the message in the outside world, thus tactical adjustments are often required.'

On the other hand, there is a strong argument in favour of having a consistent approach irrespective of

the remit of the communications. Both internal and external audiences expect a degree of consistency that boosts confidence in what the company stands for and what it is trying to achieve.

Leaving differing corporate structures and channels aside, Council members feel that there needs to be a communications backbone underlining the way the company presents itself to stakeholders, both internal and external.

“**Increasingly, we're trying not to draw a distinction. We have an external and internal comms team but we're trying to blur those lines.**

“**It is entirely consistent, so we do not draw distinctions. But how the strategy is executed may be different with external and internal audiences.**

“**There are certain things that have a greater lean in one area or another. But primarily we look at the story and how are we building reputation. Employees are a key driver of our reputation internally and externally. Our employees are the best potential advocates that we have. There are very few moments where we're able to separate the two.**

THE PLANNING CYCLE

WHEN DO REPUTATION COUNCIL MEMBERS BEGIN AND FINALISE THEIR PLANNING?

The diversity of Council members and the various industries in which they operate means that there are no typical approaches to timescales and deadlines, with company calendars starting and finishing at different times of the year.

“**Completion [of the planning] is done up to the first quarter of the following year. Why? We have a long-term planning [cycle]. So, when you look at the plan for the next year, you have to evaluate the current year and then there are a lot of things [...] that were a little bit late... because there was a lot of change, new government, changes in the law. Laws that impact our business directly and this has had a major impact on our planning. And you have to adjust it over time. That's why the process is long. It's not one planning session and that's it, we can check next year. No, it's constant, it ends up being monthly.**

THERE ARE, HOWEVER, SOME COMMON THEMES THAT ARE USEFUL TO CONSIDER:

- It tends to be an annual process with different stages across the financial year, which means that communications adapt to the needs of the business at certain points in time.
- The third and fourth quarters tend to be the periods when planning for the year ahead begins, suggesting that evidence, for example from the external market and opinion research, needs to be captured before then.
- The initial round of planning normally lasts for a quarter, implying that setting a forward strategy requires time to consult with various parts of the business.
- Council members see the communications plan as a live document, continuously up for improvement as the company navigates the year and new circumstances present themselves, meaning the job is never fully complete.

“**We're kind of in constant planning cycles. We have our one-year planning, which happens in August, September, we have three-year plans. We're always trying to make sure that we're doing a mix of short-, medium-, and long-term plans.**

“**We have a clear sense of what we want to do by the turn of the year but after our trading update and prelims we then start to finalise it.**

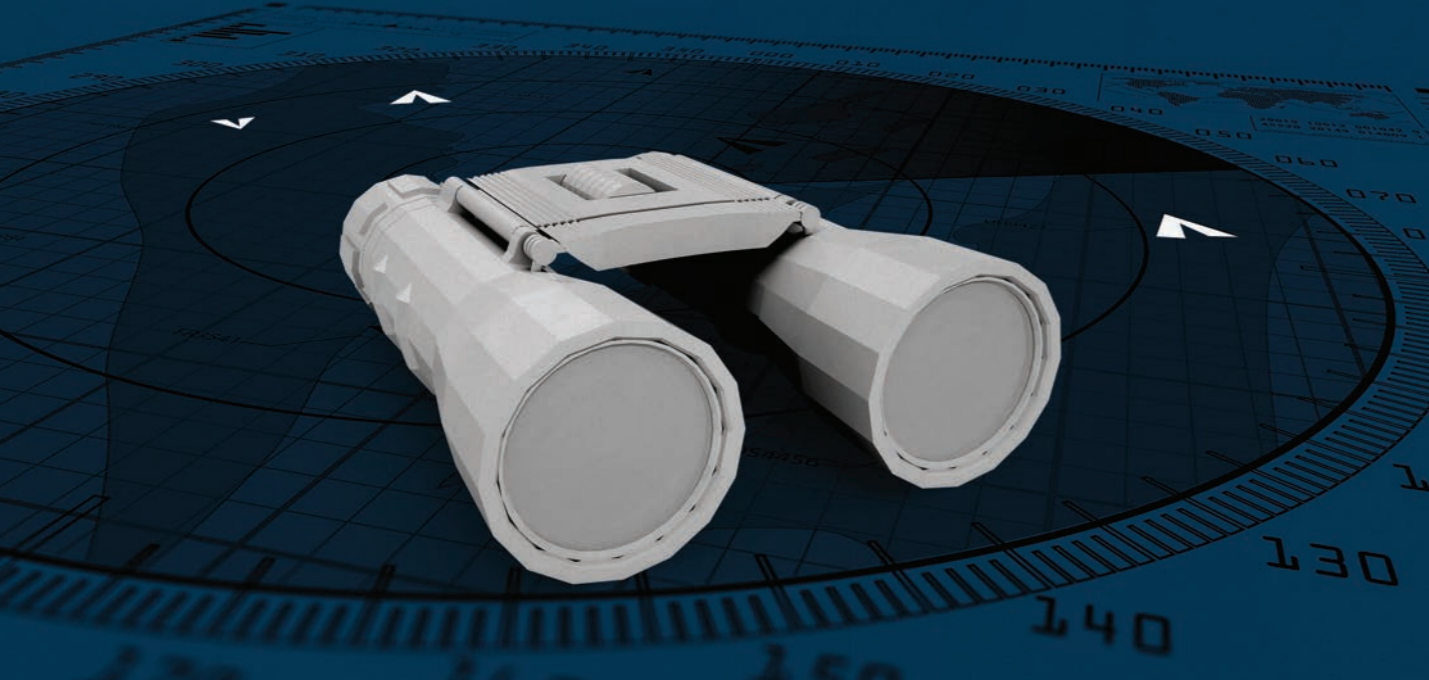

WHAT TO EXPECT IN THE NEXT FIVE YEARS

Council members expect the main changes and challenges they've identified to evolve and even become more prominent in the near future. Whilst the essentials of communications, such as building long-term, trusted relationships with key stakeholders or considering the views and expectations of various stakeholder groups will remain a constant, the environment in which corporate communicators are expected to deliver will go through further transformation.

“

It's always going to have the same principles of what is an earned story that is at the core of your strategy. That's a timeless skill and applying those stories and choreographing them. I can't really envision what the technology or the channels of the future might be, but the same disciplines around strategy and smart narrative are timeless.

Some of these changes will be driven by technological innovations, such as new channels and platforms for companies to get their voices heard and compete for attention, or processes for collaboration, with remote working among global teams being a prime example.

“

The approach is likely to remain the same, but the actions, channels and forms will have changed to accommodate the dynamics of communications and technology.

Other changes will relate to stakeholders' expectations, particularly around the need for companies to have a clear strategy in areas such as sustainability and climate change. Finally, a more insights-driven approach to communications, and the availability of vast amounts of data, has already started to have a noticeable impact in the way companies communicate.

CONCLUDING THOUGHTS

Corporate communicators are required to have a structured yet flexible communications process to navigate a complex and crowded environment. The initial planning phase is mostly useful to set the overall strategy for the year, but it inevitably needs to be adapted as circumstances and expectations evolve at an increasingly fast pace. Currently, there are already multiple inputs to consider, both internal and external. The successful corporate communicator is able to blend them all into a cohesive narrative that will support the organisation in achieving its goals.

With these trends set to develop further in the next five years, communicators need to make the case for the value of increased investment in multi-disciplinary teams and comprehensive skillsets, to ensure corporate communications continue to support and add value to the business.



EMBARKING ON THE DATA INTEGRATION JOURNEY: SMOOTH SAILING



Communicators today are in the fortunate position where data is more abundant than ever; from reputation surveys to campaign measurement tools, business intelligence to employee feedback systems, and from media analysis to owned platform insights. The options for data collection and analytics are endless. However, making sense of this data and consolidating it into a useful system, where insights can be quickly drawn and communicated to leaders throughout the organisation is a daunting task.

A variety of data sources are used by communicators today, each providing different inputs to overall reputation measurement and management programmes.

Each of these data sources has a specific purpose within the communications environment. Social and traditional media analytics can help to determine how messages

resonate and can provide intelligence regarding overall tone, sentiment, topics, and issues covered for a company versus its competitive set. Whereas issues monitoring can help a company keep abreast of regulatory issues that may impact the business environment. Reputation metrics and key stakeholder feedback can provide more detailed data about a company's reputational strengths, weaknesses, opportunities and threats, as well as a deeper understanding of what attributes will have the greatest impact on reputation.

“ Rather than looking back and only analysing what we have done, using it to inform what we could do or should do.

The use of these various data sources runs the spectrum from not being utilized at all to integrated systems providing real-time intelligence for reputation monitoring and crisis management.

“ We talk about data informed decision making, not data driven, and that is an important distinction. PR people have traded on their gut feel forever, “It feels like the right thing to do” or “It doesn’t feel like the right thing to do” and that gut instinct is really important and we shouldn’t lose that but we can’t trade on it anymore, we do have to have the data to inform the decision. It is how we interpret that data and the experience we bring to looking at that data and the gut feel that is critical. So that is why we say data informed.

% USE DATA SOURCE

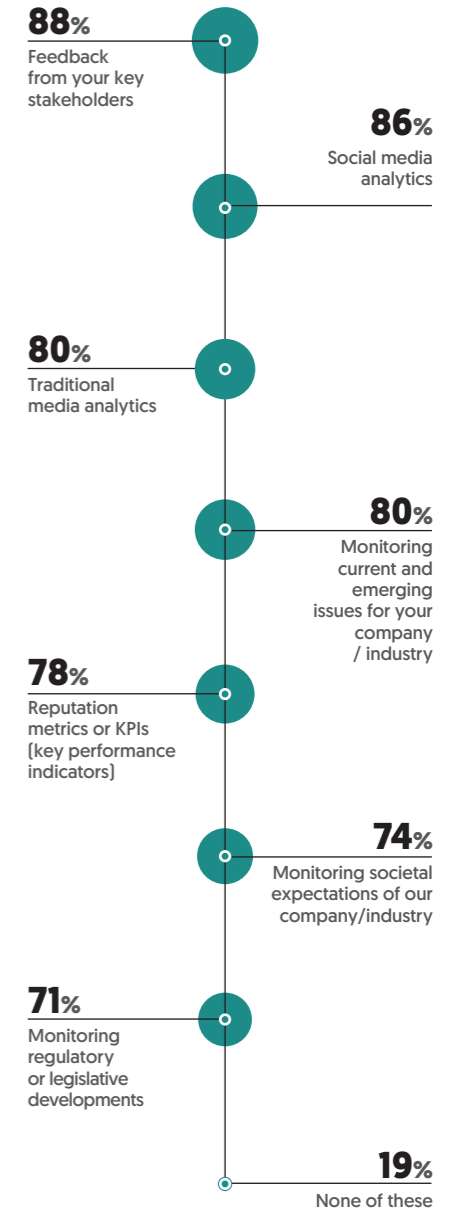

Base: 86 Council members

“

We have information spread in the organization. We are not ready to take advantage of all we have [due to a] lack of tools and resources.

“

The team uses a lot of media listening, we are just starting social media listening and if you call it a data source, our monitoring, our media monitoring of ourselves and others.

“

We have more data than we think, and we do not use it enough.

“

Live tracking of social media. I think what is critical is not to be too led by real-time data. Watch your trends but don't watch for immediate [changes].



“

We look at data to see what the best route is of telling a particular story. We're looking to see at what's cutting through. What topics of a particular campaign worked or didn't. We measure corporate reputation in 12 markets and report it quarterly.

“

When we look at research, we look at things in the immediate, mid-term, the long-term, and then the agile step in between. To start with immediate, we look at leading impressions and an understanding of where we are and how we're playing. Sentiment is an important part of that. In crisis management, we're not just looking at the value of the conversation but the velocity of the conversation.

“

The other thing is reputation tracking is important for us. We're looking at [specific stakeholders] and understanding what drives reputation for them.

With so many sources in use, how do communicators ensure they are utilizing the right data mix and taking a holistic picture into account when planning communications strategies, developing messaging, navigating today's regulatory environment, or determining whether an issue is likely to turn into a full-blown crisis?

The key is successful data integration to merge data sets and create a system that allows for easy exploration of key topics, issues, trends and reputation metrics. Robust data integration platforms have the ability to bring together real-time social media data, online and traditional media, broadcast and video content, legislative and regulatory updates, and survey data into a common platform allowing for ease of data exploration and insight identification. The days of Boolean search strings to monitor static topics have given way to machine learning and topic modelling to identify related topics and issues in real-time data streams. Alerts can identify meaningful shifts in volume or sentiment on critical topics to provide an early-warning system to alert communicators of potential issues requiring attention. When paired with frequent survey data, an integrated data system doesn't just display data side-by-side, but it instead is designed to track the key issues and attributes that have the greatest potential to impact reputation, as identified by deep survey exploration and using these as the basis for ongoing social and online media tracking.

The most sophisticated systems can utilize always-on survey data paired with real-time digital intelligence feeds to generate predictive analytics that help determine whether media stories or social content will have a meaningful impact on reputational metrics.

The takeaway from our Reputation Council members is that integrated data streams are becoming a more critical tool, allowing more timely, informed decisions on how to proactively manage reputation, navigate the issues environment, and monitor emerging crises. However, today, many communicators feel they have a long way to go before they truly have integrated data available. When asked how they would rate themselves on a 10-point scale, most put themselves somewhere in the middle – not completely siloed, but not very well integrated.

DATA INTEGRATION RATING

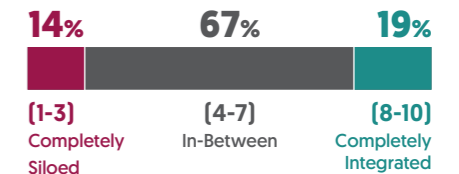

Base: 81 Council members

“It's a manual process really... through people getting together and sharing [their data].”

KEY POINTS:

01. The proliferation of data sources has put more information at communicators' fingertips, but most communicators have not fully integrated their data sources, limiting the ability to develop fully-informed strategies.

02. Social media analytics and feedback from key stakeholders are the primary data sources used in corporate communications, but may lack the comprehensive insights needed to enable the best decision-making.

03. Reputation Council members desire greater data integration, but most are uncertain of the best methods to do so.

“ As a business we are still learning how to use data and what does it mean. Data is useless without the analytics. **”**

“ Honestly, the function isn't run by people who tend to be very good at data. **”**

“ Data is the fundamental piece of information that [our internal stakeholders] are going to respond to and make a decision on. But you still need to tell a story and have a narrative. **”**

The data integration and analytics journey is one many communicators are just beginning to embark on, but one thing is certain – those who are able to harness the power of today's data streams and analytical capabilities will be able to make smarter, faster decisions that allow them to separate true crises from turbulence, to capitalise on unique opportunities, and to design more effective strategies that result in positive reputational impact.

“ This is one of our biggest opportunities – looking at how to bring all the sources together to draw intelligence and insights. [It's a] huge opportunity on our priority list and we haven't gotten to it yet. **”**

“ The biggest growth area in corporate relations is your ability to analyze data effectively and make the right decisions. This will eventually be a part of each team within the corporate affairs team. **”**

ONLY 19% OF COUNCIL MEMBERS FEEL THEY HAVE INTEGRATED DATA IN THEIR COMMUNICATIONS



“ In comms it is still very siloed at the moment. We have a data analytics team, a data science team who are pulling all data together from all our products and looking at it from an operational maintenance point of view, but from a comms point of view we are still a long way off. **”**

“ We have a good dashboard, but we really lack this type of data integration. **”**

“ We're using AI and data lakes rather than trying to get a standard system in which everything goes into but actually has spiders that are able to crawl through. We're looking into the extent to which we can predict how a story will impact our reputation. **”**

While data integration can take time and care to execute in a way that will be most beneficial to each organisation and comms team using it, data is not enough on its own. It's

critical that communicators have the expertise and resources available to extract insights, identify issues and trends, and be able to translate the data into a narrative that supports their objectives. Strong partnerships with market insights and analytics and working collaboratively with data analysts to be sure they understand the mission and objectives of the communications team will help to ensure these tools are utilized to the best of their ability.

KEEP THE CONVERSATION GOING

This year we've included a selection of emerging issues that Reputation Council members have told us they are thinking about and would like to explore further.

The re-emergence of the activist movement. We are seeing the climate change Extinction Rebellion side of things, we have seen various other groups – in France pretty much all of last year, we are seeing in Hong Kong, Chile, there are various activist groups who are taking to the streets.

The biggest thing linked with people in my industry, communications (is that), we often make the mistake of thinking everyone thinks the way we do. So, you have an individual who could be in Islington, degree-educated and you have someone on low pay using food banks; what do they want to hear from you? To truly, truly understand the broadest spectrum of society as possible.

The challenge for people in communications remains today because there's such a plethora of voices out there. It's being able to separate the wheat from the chaff. The ability for a voice to get lots of followers doesn't necessarily mean it's a significant voice long-term. It's this weighting issue, I think that's really a challenge. Some of us make decisions because of the level of noise rather than the source of the noise.

The rise of populism, that is definitely going to have a big impact on us as businesses. We are going to be seen as part of the problem, and in a state of continued flux which we will continue to be in for the foreseeable.

It is always really interesting (for me) to see how other communications functions operate, in the most boring sense of the word, because I think by sharing best practices is how we set ourselves up for success

I would love to know a little bit more about how gender reporting is impacting reputation?

Generation Z as new communicators: What is the shift, which (new) skills will be necessary for communicators to reach the younger generations? What are the skills future communicators need (i.e. it is not about spelling and good writing skills anymore, they now need a feeling for stories, perspectives, visual storytelling, big pictures, etc.)?

If you'd like to know more about these issues and are interested in getting involved in the conversation, please let us know – the Ipsos Corporate Reputation team will be pleased to facilitate. Please email us at: reputation@ipsos.com

IPSOS CORPORATE REPUTATION

For business leaders who aspire to better decision-making in reputation, corporate communications and corporate policy development, the Ipsos Corporate Reputation team is the insight industry's most trusted source of specialist research and guidance.

The Ipsos Corporate Reputation team helps organisations build resilient reputations and stronger relationships.

OUR APPROACH IS TAILORED AND CAREFULLY DESIGNED TO MEET EACH CLIENT'S INDIVIDUAL NEEDS, AND OUR RESEARCH DIRECTLY DRIVES BUSINESS PERFORMANCE:

- Measuring reputation performance relative to peers
- Identifying the drivers that create reputational value
- Defining the stakeholders who influence reputation
- Shaping a stakeholder engagement strategy
- Building communications campaigns and measuring impact
- Understanding future opportunities and risks around reputation
- Measuring the impact of and responding to a crisis
- Clarifying the actions necessary to deliver on strategic objectives

This support helps organisations strengthen their reputation capital – the ability of a brand to command preference in the marketplace – and optimise its relationships across its stakeholders.

FOR FURTHER INSIGHT AND ANALYSIS FROM THE IPSOS CORPORATE REPUTATION TEAM

Visit us at:
reputation.ipsos.com

Follow us on Twitter at:
twitter.com/ipsosreputation

To explore previous Reputation Council reports, please visit:
reputation.ipsos-mori.com/download-our-reports

THE TEAM

CONTRIBUTORS:

Carmen Dato
Guillermo Fernandez
Guto Hunkin
Jason McGrath
Matthew Painter

Michael Granleese
Milorad Ajder
Simone Williams
Trent Ross

REPUTATION COUNCIL MANAGER:

Alex Baumont de Oliveira

REPUTATION COUNCIL PARTICIPANTS 2020

Name	Organisation	Role
Simona Giorgetti	A2A	Director of Corporate Communication and Media Relations
Louise Fernley	AB InBev	Public Relations and Communications
Carol Colorado	ABInBev	Legal y Asuntos Corporativos
Louise Bryant	Aggreko	Director of Investor Relations and Corporate Affairs
Lisa Harrington	AGL Energy	Executive General Manager, Stakeholder
Antonella Massari	AIPB	Segretario Generale
Takayuki Saito	Ajinomoto Co., Inc.	General Manager, Global Communications Dept.
Jodie Read	Alcoa	Director Corporate Affairs, Australia
Carlos Eduardo Pignatari Filho	Ambev	Head of Social Impact
Cesar Vargas	Anheuser-Busch	Vice President, Legal and Corporate Affairs
Gisela Lindstrand	Atlas Copco	SVP Corporate Communications and Governmental Affairs
Raj Kumar	Aviva	Global Director - Corporate Reputation & Brand Governance
Daniela Marques Grelin	Avon	Communications Director
Alex Torres	Banco Pichincha	Institutional Image Administrator
María Such Andrés	BBVA Group	Reputation & Responsible Customer Experience Director
Ricardo Rivera	Best Buy Mexico	Marketing, Public Relations and Government Affairs Director
Tony Cudmore	BHP	Group Sustainability & Public Policy Officer
João Veloso Jr	BMW Group Brasil	Head of Corporate Communications Brazil
Grant McLaughlin	Booz Allen Hamilton	Vice President of Corporate Affairs
Frank Mantero	Bunge	Vice President, Global Communications
Nuria San Román Navarro	Canal de Isabel II	Communication Director
Florence Marin	Cartier	Corporate Communications Director
Julian Hunt	Coca-Cola European Partners	Head of Public Affairs and Communications

Name	Organisation	Role
Rosa Yagüe	Coca-Cola European Partners	Communications Director at Coca-Cola European Partners Iberia
Vance Merolla	Colgate Palmolive Company	Worldwide Director, Global Sustainability
Delphine Dahan-Kocher	Constellium	Vice President - Group External Communications and Public Affairs North America
Matt Anchin	Consumer Reports	Chief Communications Officer
Marco Antonio Ocando	COPA Airlines	Sr. Director – Marketing, Communications and eCommerce
Shirley Powell	Cox Automotive	SVP, Communications and Industry Relations
Yoshitake Katayama	Daikin Industries, Ltd.	Department Manager, Publicity Group, General Affairs Dept.
Masahito Yoshizawa	Daikin Industries, Ltd.	Manager, CSR & Global Environment Center
Tomoko Nakagawa	Daikin Industries, Ltd.	CSR Group Leader, CSR & Global Environment Center
Michael Neuwirth	Danone Company	Senior Director of Public Relations
Rich Jeffers	Darden Restaurants	Senior Director, Communications
Armelle Weisman	Deloitte	Partner Sustainable Development
Michael Schlechtriem	Deutsche Telekom AG	Corporate Communications VP Digital Transformation & Development
Dominic Redfearn	Diageo	Global Brand and Communications Director
Clare Harbord	Drax	Group Corporate Affairs Director, Drax
Fergus Campbell	eBay	Head of Corporate Communications
Denise Coelho	Edenred	Marketing Director
Cristina Parenti	Edison	Head of External Relations and Communication
Amy Hytowitz	Edwards Lifesciences	Senior Director, Global Communications
Jacob Broberg	Electrolux Professional	Senior Vice President Investor Relations and Communications
Dr. Jens Schreiber	EnBW Energie Baden-Württemberg AG	Senior Vice President Corporate Communications and Corporate Marketing
Henrik Øinaes Habberstad	Equinor	Creative Director
Valerie Sauteret	Europcar Mobility Group	Group Communication Director
Tor Odland	Forbrukerrådet	Director Communications & Digital Services
Mike Scott	GE Digital	Commercial Communications Director
Will Spiers	GE Healthcare	Global Head of External Communications and Reputation
Pedro Moraes Torres Pinto	Gerdau	Head of Corporate Communications
Helge Thoresen	Gjensidige Insurance	Communication Director
Martha Kavanagh	Glanbia	Head of Media Relations
Ramiro Sanchez	Google	Country Marketing Director - Spain & Portugal
Francisco Rodríguez Daniel	Grupo Financiero Banorte	Executive Director of Corporate Communications
Paul Pellizzari	Hard Rock Care	Vice President Global Social Responsibility
Fábio Mincarelli	Henkel do Brasil	Head of Corporate Communication
Hans Daems	Hitachi Europe	Group Public Affairs Officer, EMEA

Name	Organisation	Role
Atsushi Konno	Hitachi, Ltd.	General Manager, Group Brand Strategy Department, Corporate Brand & Communications Division
Stina Sandell	Holmen	Executive Vice President Sustainability and Communications
Tim Shortill	HOOPP	Senior Vice President, Strategy & Stakeholder Relations
Jeff Dahncke	HP	Head of Corporate Communications
Morgan Bone	HSBC	Global Head of External Communications
Ruiqi Lin	Huawei Technologies Co., Ltd	Senior Vice President
Bryce Davies	IAG	Executive Manager - Corporate Relations
Kai Boschmann	International SOS	Chief Marketing & Communications Officer
Viveka Hirdman-Ryrberg	Investor	Head of Corporate Relations, Sustainability and Communications
Felipe Starling	Ipiranga Produtos de Petróleo	Head of External Affairs and Sustainability
Leandro Fonseca Mode	Itaú Unibanco	Chief Communications Officer and Government Relations
Sarah Colamarino	Johnson & Johnson	VP, Corporate Equity
Jill Feldon LaNouette	Kaiser Permanente	Vice President, Marketing, Communication, and Community Relations
Mark Harrad	Kaplan, Inc.	VP Communications
Steve Lombardo	Koch Industries	Chief Communications and Marketing Officer
Takenori Takahashi	Konica Minolta, Inc.	Group Executive, General Manager, Corporate Sustainability Division
Mami Iwamoto	Konica Minolta, Inc.	General Manager, Corporate Communications Office, Corporate Diversity & Inclusion Office
Tom Goddard	KPMG	Head of Strategic Communications
Jessica Pantages	Layton Construction	Vice President, Marketing and Communications
Torod B. Neptune	Lenovo	Chief Communications Officer
Charlotte West	Lenovo	Executive Director, Global Corporate Communications
Sarah Larvor	Lloyds Banking Group	Group Reputation, Strategy & Planning Director
Kevin Groh	Loblaw Companies Limited	Senior Vice President, Corporate Affairs and Communication
Jon Sellors	LV	Head of Corporate Communications
Victoria McKenzie-Gould	Marks and Spencer plc	Corporate Communications Director
Andy Pharoah	Mars	Vice President, Corporate Affairs and Sustainability
James Issokson	MasterCard Worldwide	Senior Business Leader, Reputation and Issues Management
Gianluca Randazzo	Mediolanum	Head of Sustainability
Sara Sizer	Mondi	Group Communication & Marketing Director
Matthew Vander Laan	Monosol, a Kuraray Division	Head of Corporate Communications and Public Affairs
Julian Regan-Mears	Neptune Energy	Director of Corporate Affairs
Lisa Gibby	Nestlé	Vice President, Head of Corporate Communications
Liz Caselli-Michael	Nestlé	Digital Corporate Communications Lead

Name	Organisation	Role
Allison McClain Joyce	Nixon Peabody LLP	Chief Communications Officer
Dave Massey	O2 (Telefonica UK)	Senior Corporate Communications Manager
Håkon Mageli	Orkla	Group Communication Director
Aimee Goldsmith	P&G	Associate Director, Company Communications, Northern Europe
Tom Steiner	Pearson	Vice President, Corporate & Financial Communications
Gian-Carlo Peressutti	PepsiCo	Vice President, Global Communications
Dana Gandsman	Pfizer	Senior Director, Reputation Communications
Valerie Lauthier	Pierre & Vacances-Center Parcs	Group Communication Director
Rafael F. de Oliveira	Pirelli Latam Participações Ltda	Corporate Affairs Manager
James Newman	Playtech	Director of Corporate Affairs
Roger Lowry	QBE Insurance	Head of Communications and Marketing
Emily Riley	Radian Group, Inc.	Senior Vice President, Corporate Communications and Investor Relations
Peter Edwards	RB	External Communications Director
Duncan Young	RBS	Head of Business Communications
Brad Haynes	Rio Tinto	Vice President Corporate Relations
Jamie Nicholson	Roche	Corporate Affairs Manager
David Flynn	Roche	Head of Public Relations
Isabel Garcia Sanchez-Valiente	Santander Group	Brand & Culture Director
Will Clarke	Sensis	Head of Communications
Rob Colmer	Shell International	External Relations Manager, STAR [Sustainability Transparency And Reporting], Shell International
Dr. Heike Bernard	Siemens	Head of Research at Siemens Communications
Kelly O'Rourke	South32	Vice-President of Corporate Affairs
Noleen Dube	South32	Reputation and Corporate Affairs Director
Regina Maia Lopes da Cruz	Souza Cruz	Head of Corporate Communications
Catherine Kress	Stallergenes Greer	Head of Communication
Barry Neville	Standard Chartered	Global Head Content and Campaigns
Judith Sparkes	Suncor	Vice President, Communications
Abhinav Kumar	TATA Consulting Services	Chief Marketing & Communications Officer – Global Markets
Kari Janavitz	TE Connectivity	Chief Marketing Officer
Fiona Maharg	Telefónica	Director of International and Financial Media Relations
Eduardo Puig Aznar	Telefónica Group	Director of Stakeholder Engagement and Corporate Reporting
Gry Nordhus	Telenor	SVP, Head of Group Communications
Tully Smith	Telstra	Corporate Affairs Manager

Name	Organisation	Role
Mike Phifer	The Coca-Cola Company	Senior Director, Global Corporate Reputation
Stefanie Effner	The Coca-Cola Company	Head of External Communications
Luca Josi	Tim	Brand Strategy, Media & Multimedia Entertainment Director
Åsa Barsness	TV4	Chief Communications Officer & Chief HR Officer
Jessica Sobel	Unilever	Corporate Strategy Director - North America
Michele Quintaglie	United Technologies	Global External Communications and Marketing Head (Corporate)
Yolanda Franco Bonilla	Universitat Oberta de Catalunya	Director of Brand, Reputation & Web Strategy
Cristina Ontoso	Vía Célere	Director of Marketing, Communication and Customer Experience
Stacey Zolt Hara	Visa	Vice President, Head of Global Reputation Management and Public Affairs
Paul Cohen	Visa	SVP Chief Communications Officer
Alexander Leinhos	Vodafone	Company Spokesman, Head of External Communications
Ed Mayer	Voya Financial	Vice President, Corporate Communications
Gabriela Buenrostro	Walmart de México	Head of Corporate Communications
Matthew Grossman	Walt Disney Company	Vice President Corporate Communications, Publicity & Corporate Citizenship and GM Healthy Living (EMEA)
Maria Claudia Villaboim Pontes	Weleda Brasil	CEO
Naomi Flutter	Wesfarmers	Executive General Manager, Corporate Affairs
Maribel Ferrero	Wizink	Head of Brand, Communication & CSR
Paul Lyon	Wolters Kluwer	Global Director of Corporate Communications: Marketing/Comms/Planning
Peter Metcalfe	Woodside Energy	General Manager Government and External Affairs
Jieyun Xu	Xiaomi Corporation	Public Relations General Manager
Akihiro Nakanishi	YANMAR CO.,LTD.	Divisional Manager, Public Relations Group, Brand Communication Division
Pascale Marchand	ZipRecruiter	Vice President, Head of Global Communications
Bill Price	Zoetis	Vice President and Chief Communications Officer

150 PARTICIPANTS WERE INTERVIEWED AS PART OF THIS YEAR'S REPUTATION COUNCIL. FOUR PEOPLE REQUESTED THAT THEIR PARTICIPATION REMAIN ANONYMOUS, THEREFORE 146 PEOPLE ARE SHOWN HERE.

FURTHER INFORMATION

MILORAD AJDER

Global Service Line Leader,
Ipsos Corporate Reputation

t: +44 (0) 20 7347 3925
e: milorad.ajder@ipsos.com

TRENT ROSS

Chief Research Officer
Corporate Reputation

t: +1 202-420-2023
e: trent.ross@ipsos.com

reputation.ipsos.com

🐦: @ipsosreputation
e: reputation@ipsos.com



GAME CHANGERS

